

Barras:

La longitud o largo máximo de una barra es 1 metro y según el diámetro se ofrece el corte mínimo.

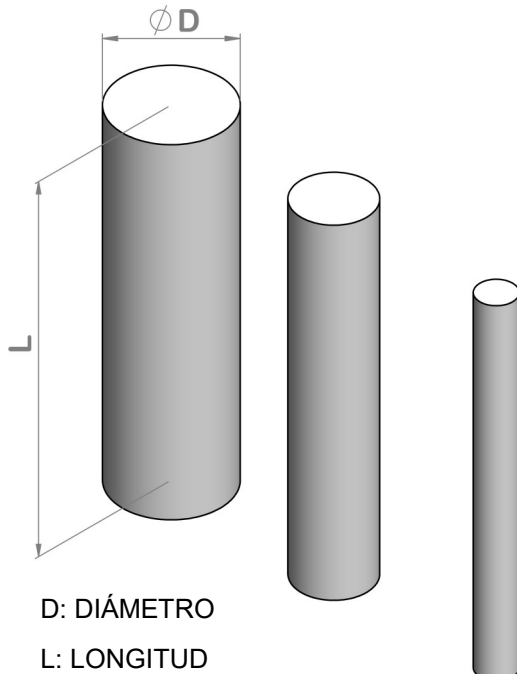

| D (mm) | Peso Lineal (kg/m) | Corte Mínimo L (cm) |
|--------|--------------------|---------------------|
| 20 | 0.45 | 100 |
| 25 | 0.68 | 100 |
| 30 | 0.98 | 50 |
| 35 | 1.35 | 50 |
| 40 | 1.72 | 20 |
| 45 | 2.16 | 20 |
| 50 | 2.65 | 20 |
| 55 | 3.18 | 20 |
| 60 | 3.89 | 20 |
| 65 | 4.51 | 20 |
| 70 | 5.32 | 10 |
| 75 | 5.91 | 10 |
| 80 | 6.89 | 10 |
| 85 | 7.76 | 10 |
| 90 | 8.54 | 10 |
| 100 | 10.65 | 5 |
| 110 | 13.08 | 5 |
| 120 | 15.44 | 5 |
| 130 | 18.20 | 5 |
| 140 | 20.92 | 5 |
| 150 | 24.08 | 5 |
| 200 | 41.50 | 5 |

Nota: 1 m = 100 cm = 1000 mm

Planchas:

El largo y ancho máximo es: 2m x 1m (L x A)

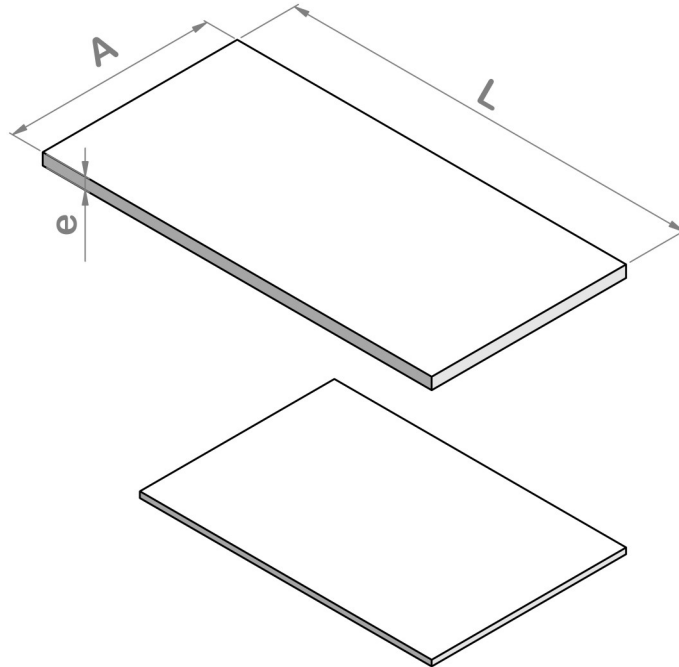

L: LARGO
A: ANCHO
e: ESPESOR

| e (mm) | Peso de plancha 2m x 1m (kg) |
|--------|------------------------------|
| 2 | 6 |
| 3 | 9 |
| 4 | 12 |
| 5 | 16 |
| 6 | 18 |
| 8 | 24 |
| 10 | 30 |
| 12 | 37 |
| 15 | 45 |
| 20 | 61 |
| 25 | 75 |
| 30 | 84 |
| 35 | 102 |
| 40 | 116 |
| 45 | 135 |
| 50 | 150 |
| 65 | 185 |
| 75 | 211 |
| 100 | 283 |

Nota: 1 m = 100 cm = 1000 mm